



Engineering Excellence!

Reno A & E
4655 Aircenter Circle
Reno, NV 89502-5948 USA
Telephone: (775) 826-2020
Fax: (775) 826-9191
Website: www.renoae.com
E-mail: contact@renoae.com



OPERATING INSTRUCTIONS FOR
Models AVI-X / AVI-XP / AVI-XP36
AUTOMATIC VEHICLE IDENTIFICATION TRANSMITTER

I. General Description:

The Automatic Vehicle Identification (AVI) Transmitter is a small, self-contained device that is easily installed on the underside of a vehicle. This device automatically and continuously transmits a uniquely coded signal when it is connected to a vehicle's electrical system. This signal is picked-up by an antenna (typically mounted in the road surface) connected to an automatic vehicle identification receiver that is capable of decoding the transmitted signal. See Automatic Vehicle Identification Receiver operating instructions for details on antenna installation.

The Model AVI-X is a 12 Volt DC unit, the Model AVI-XP is a 24 Volt DC unit, the Model AVI-XP36 is a 36 Volt DC unit.

NOTE: To ensure reliable, long-term operation, all electronic components in this device are encapsulated in a rugged, epoxy-based resin. In the event of failure, this device is nonrepairable.

II. Installation Instructions:

- Proper location and installation are essential for correct operation of this device. In order to ensure the most consistent and earliest detection of the vehicle, select a location on the underside of the vehicle that is in front of the front wheels and behind the front bumper. Mount the device securely. Make sure that it is oriented properly with the large puck shaped portion pointing downward and the mounting bolt vertical. It should be located as low as practical on the vehicle to provide an uninterrupted signal path to the receiving antenna. **It is critical that the AVI-X transmitter is mounted in a location that does not make it vulnerable to possible damage from any form of road obstacle or debris.** It is recommended that the device be mounted to a strong structural member (on the underside of the vehicle) that does not obstruct the transmission signal path to the receiving antenna. For best results, the sides and top of the device should be at least 2 inches away from any vehicle structural member. Generally, the mounting height will be 12 to 18 inches above the pavement for most cars and small trucks. Large trucks may, because of greater over-the-road clearance, require greater mounting heights. Contact Reno A & E for special considerations when using a mounting height greater than 36 inches.
- Do not install the transmitter or its cable near moving parts or in areas exposed to temperatures exceeding 180 degrees Fahrenheit (82 degrees Centigrade). All mounting hardware supplied with this device is corrosion resistant stainless steel.
- Route the cable into the driver's compartment, avoiding sharp edges, hot spots, and abrasion points. The transmitter does not contain any form of internally fused protection. A one ampere (1A) fuse must be installed in series with the line from the power source. **Use a fast-blow fuse only. Never use a slow-blow fuse.** The fuse should be suitable for 12, 24, or 36 Volts DC input only, depending on model. The white wire must be connected (through the fuse) to the positive power source. The black wire must be connected to the negative power source (ground).

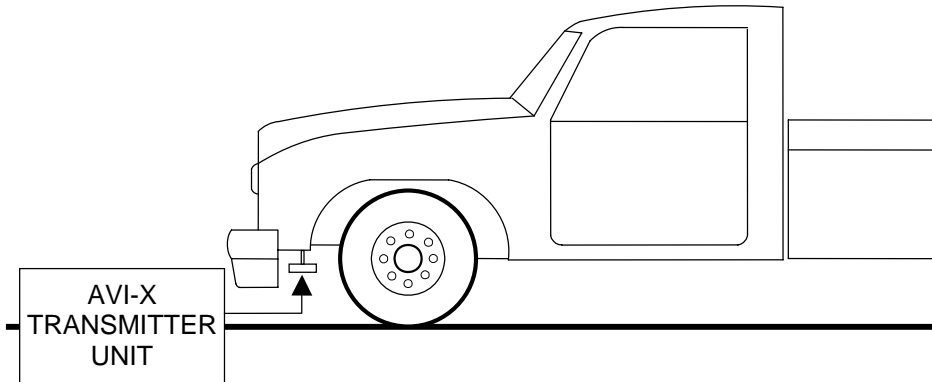

NOTE: The location of the AVI-X transmitter shown above is for reference only. **It is critical that the AVI-X transmitter is mounted in a location that does not make it vulnerable to possible damage from any form of road obstacle or debris.** The transmitter should be mounted in front of the front wheels and behind the front bumper. The actual location will depend on the specific vehicle to which the transmitter is being mounted.

- Whenever possible, the transmitter should be connected to the accessory position of the ignition switch. If this is not possible, a separate switch must be installed on or under the dashboard to turn off the transmitter when the vehicle is not running, eliminating the constant drain on the battery. When used on emergency vehicles, the transmitter may be connected through the switch for the emergency lights.
- Make certain that all electrical connections are electrically and mechanically secure. All connection points must be clean. This is extremely important for the ground connections. Thoroughly clean the ground point with fine sandpaper or emery cloth. All terminals installed on the wires must be properly and securely crimped. For an even stronger and more secure connection, the crimped connections may be soldered (recommended). The screw or bolt used to make the ground connection should be securely tightened. Use a lock washer or similar hardware to ensure tight, secure connections if the transmitter is mounted in a vibration prone environment. Coat the finished connection with a protective sealant to prevent potential moisture and salt damage.

NOTE: Failure to adhere to these precautions can result in the loss of transmitter operation without warning or indication and may void the factory warranty.

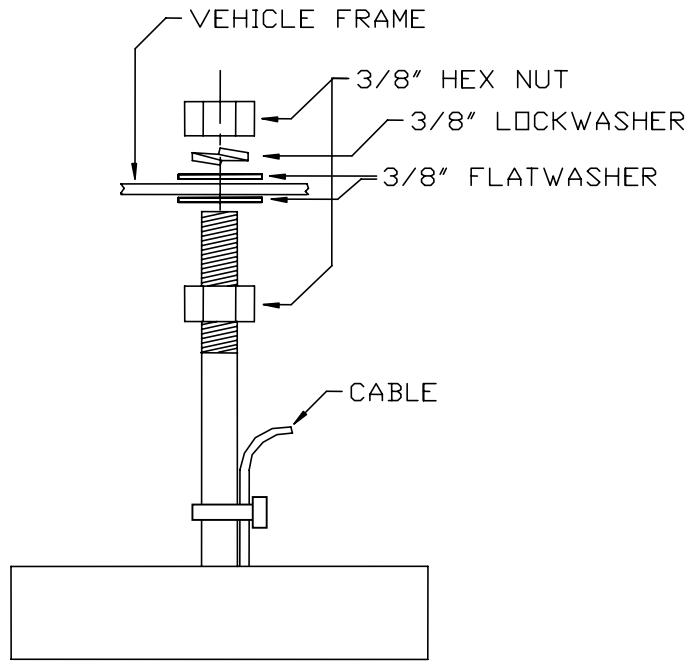
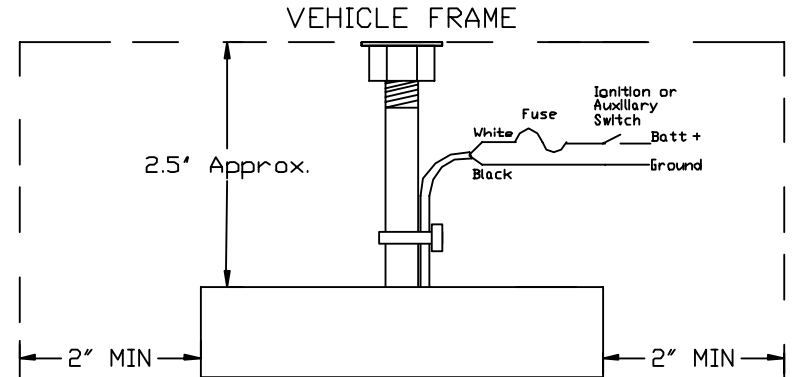

Fig. 1

Install parts in the order shown above.



Locate on vehicle as shown above and on the next page.